

RF Over IP

Digitize and transport Analog RF Spectrum
over an IP network



ATCI

evertz

QUINTECH

End-to-End RF Solutions

Antenna Site

Equipment Room

MAGNUM-OS
Monitoring & Control Software

Network

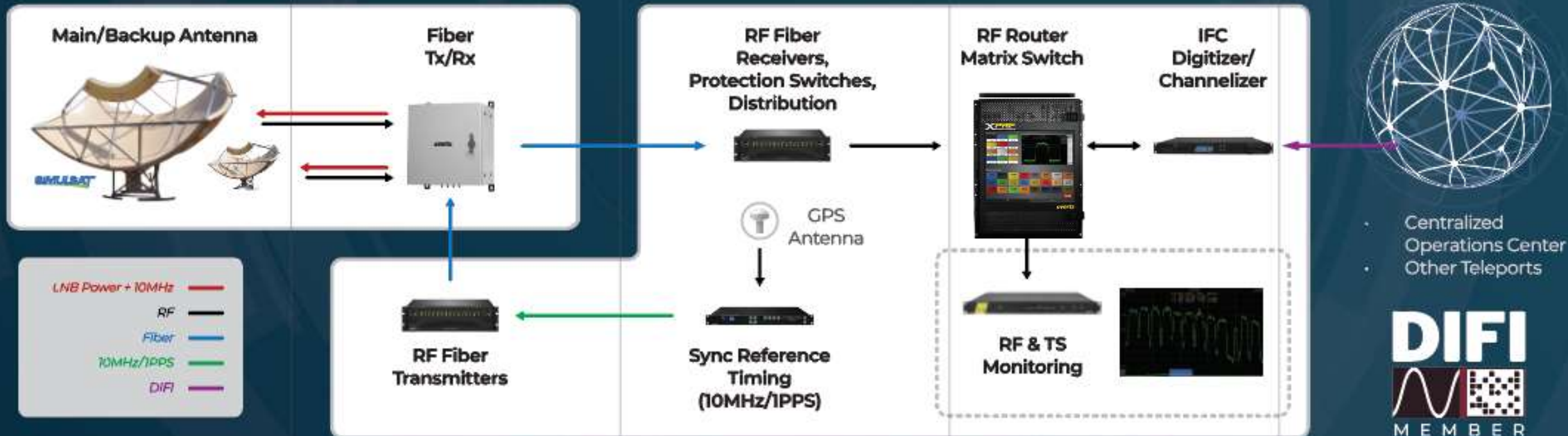

RF Evolution: Game Change in RF Industry

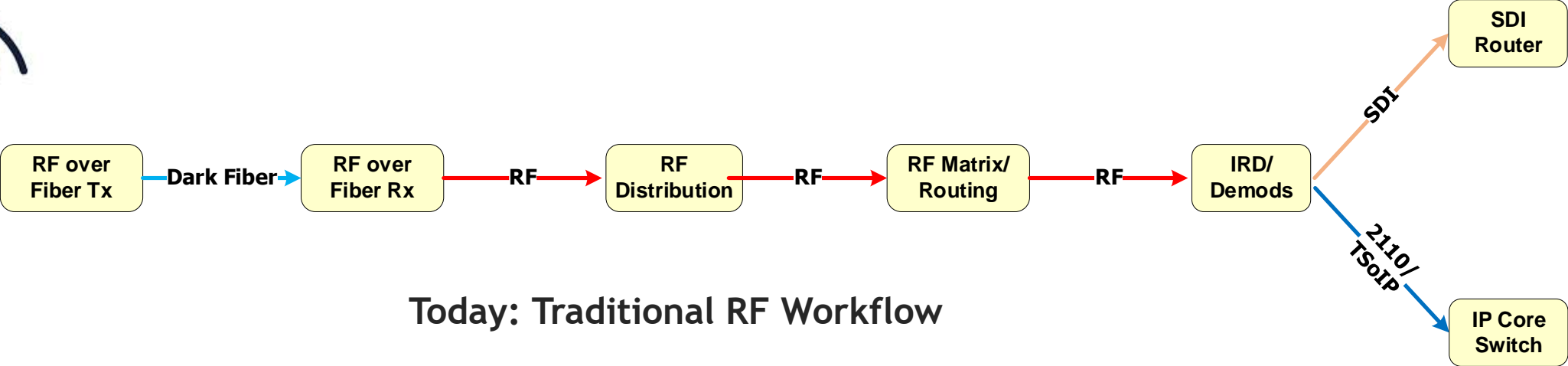

**Digital RF
(High- IP Bandwidth Feeds)**

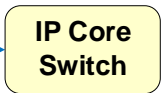

Vision: Future RF Workflow



RFoIP Applications & Use Cases



RF over IP - Applications & Benefits - **Long Haul Transport**

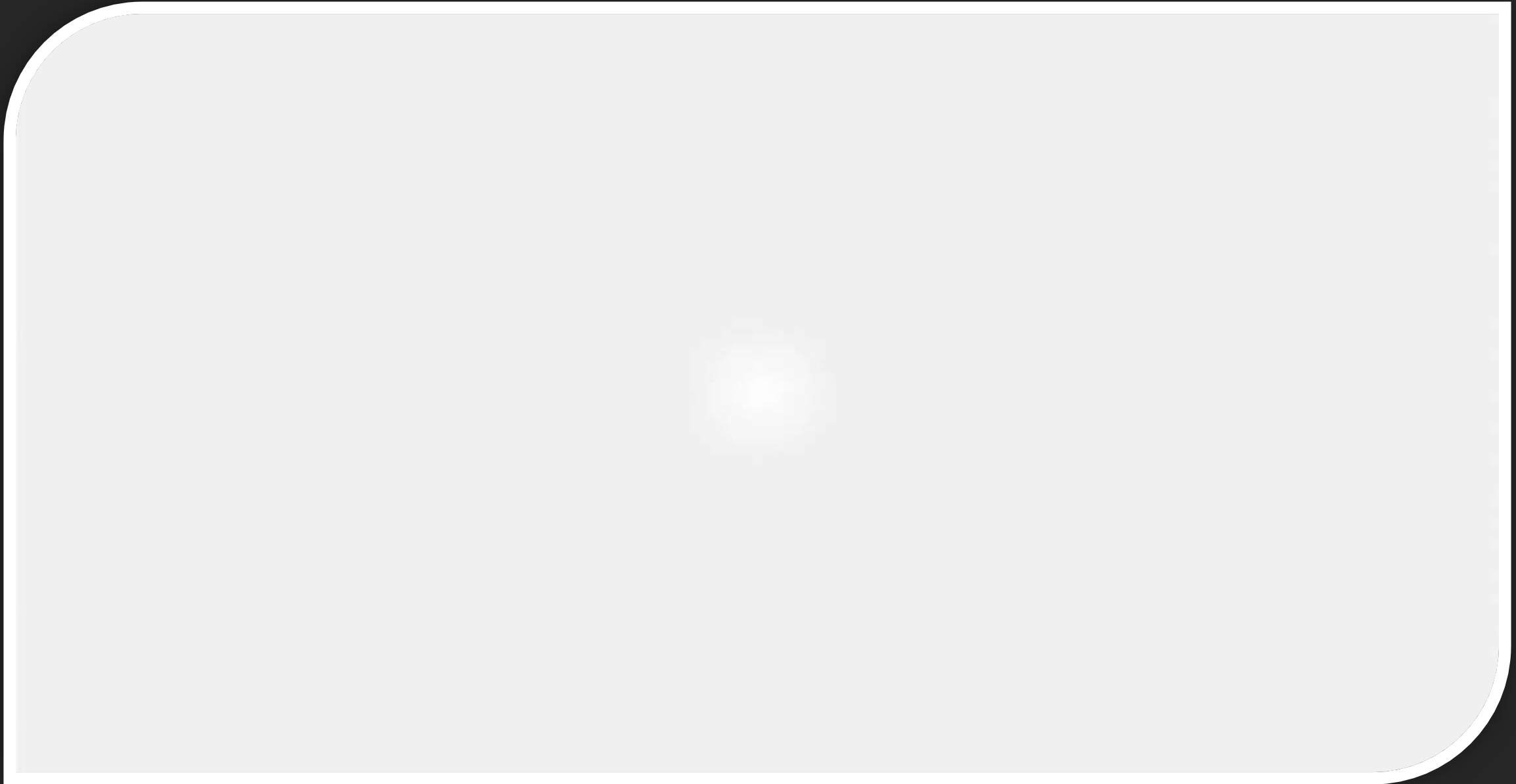

RF over IP - Long Haul Transport Examples



Backhaul RF Signals from ESPN in Bristol Facility to DC3 Building in Texas

LUMEN®

Transport Latin American feeds using Lumen Network from Atlanta to Arizona



RF over IP - Applications & Benefits - Centralization of Operations



- ✓ Simplify & Improve Operational efficiencies
- ✓ Lower Operational & Maintenance Cost (OPEX)
- ✓ Reduce Physical Real-estate



RF over IP

Application & Benefits:

Disaster Recovery & Rain Fade Mitigation



- ✓ Guaranteed Service
- ✓ Meet strict SLA requirements

RF over IP - Applications & Benefits - **Site Diversity**

- ✓ Drastically increase antenna placement flexibility
- ✓ Reduce antenna cost & physical space real-estate
- ✓ Facilitates new services (RF over IP as a Service)

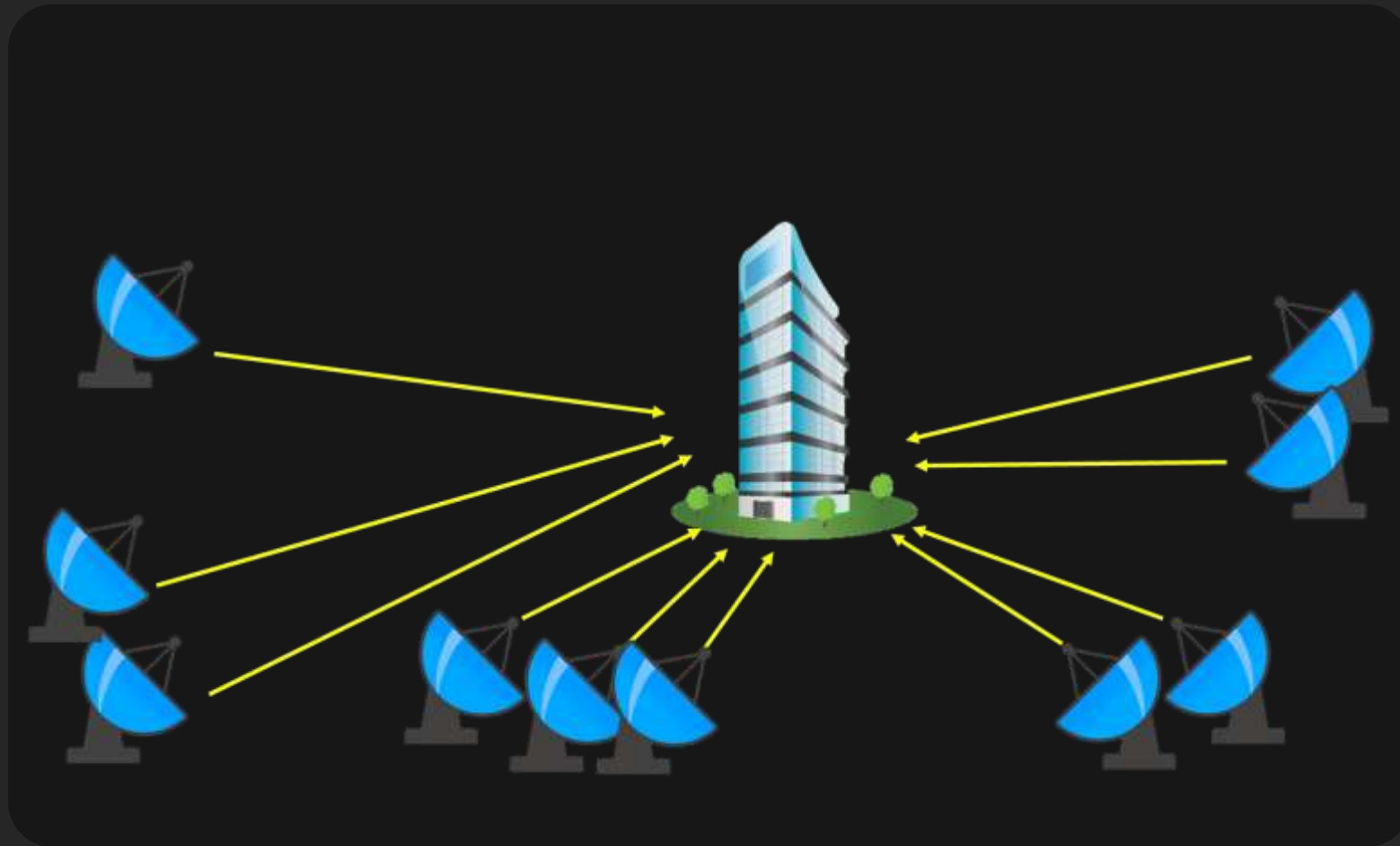

RF over IP - Applications & Benefits - Mitigation of 5G Interference



Downlink Signal 350Km
away from cell tower to
Sky's facility





Our Solution



RF over IP/ Digitized RF

Our Solution - Overview



- Modular solution in
 - 1- 600MHz Real-time Bandwidth/Channel (Selectable)
 - Software License for 1GHz Support wideband input.
 - Narrowband Applications: one or few transponders
 - Wideband Applications: Full polarity
- 950-2150MHz Range
 - L-Band & Extended L-band
 - Agnostic to signal types
- 4-16 bit Sample Size (User control)
 - Higher Sample Size>> higher IP bandwidth
- Dual 10/25/100 GBE Throughput (QSFP Trunk Ports)
 - Support both Narrowband and Wideband applications



Quad RF to IP Conversion



Quad IP to RF Conversion



Quad Bi-directional RF to IP Conversion



RF over IP

Density



28 Unidirectional or
Bidirectional Conversions
in 3RU

8 Unidirectional or
Bidirectional Conversions
in 1RU



RF over IP

DIFI Standard/Protocol



- DIFI/Vita 49.2 IP Standard
 - Digital Intermediate frequency Interoperability
 - Software defined radio (SDR) protocol
- Evertz is proud to have participated in both DIFI plug fest in Sep 2023 and June 2024
 - Make (DIFI) Standard open and transparent standard.
 - RF over IP will be a game changing evolution for the RF industry.



MAGNUM-OS



Challenges



RF over IP Challenges



- Availability of high throughput IP Bandwidth

Digitized RF – IP Bandwidth Approximations					
RF Bandwidth	Sample Sizes (Gbps)				
	4	6	8	12	16
10 MHz	0.10	0.15	0.20	0.31	0.41
36 MHz	0.37	0.55	0.73	1.10	1.47
100 MHz	1.02	1.53	2.04	3.06	4.08
200 MHz	2.04	3.06	4.08	6.12	8.16
400 MHz	4.08	6.12	8.16	12.24	16.32
500 MHz	5.10	7.65	10.20	15.30	20.40
600 MHz	6.12	9.18	12.24	18.36	24.48

Broadcast Downlink
Uplink or Military/Gov

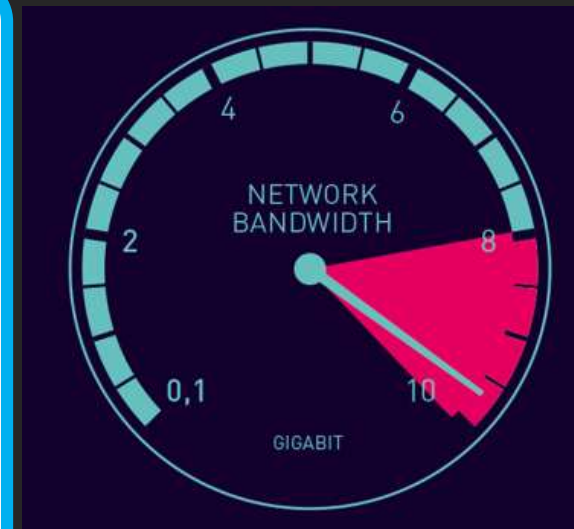

- Digitization of unwanted Transponders
 - Waste of IP Bandwidth

Wideband Signal Processor

Channelizer/De-Channelizer - 670WSP-HW Overview

- FPGA Processor with WSP APP and licenses.
- User-selectable Wideband Channel bandwidth up to 600MHz for processing.
 - Software License for 1GHz Support wideband input.
- User-selectable Narrow Channel bandwidth 0.6 - 75Mhz
 - Up to 250Mhz Bandwidth with 1GHz License.
- Sample Size 4-16 bits
- 6x100GbE throughput (QSFP trunk ports) per blade
 - 3 Main + 3 Backup



EV670-WSP-HW

(Front View)



Digital RF Example



4 Polarity

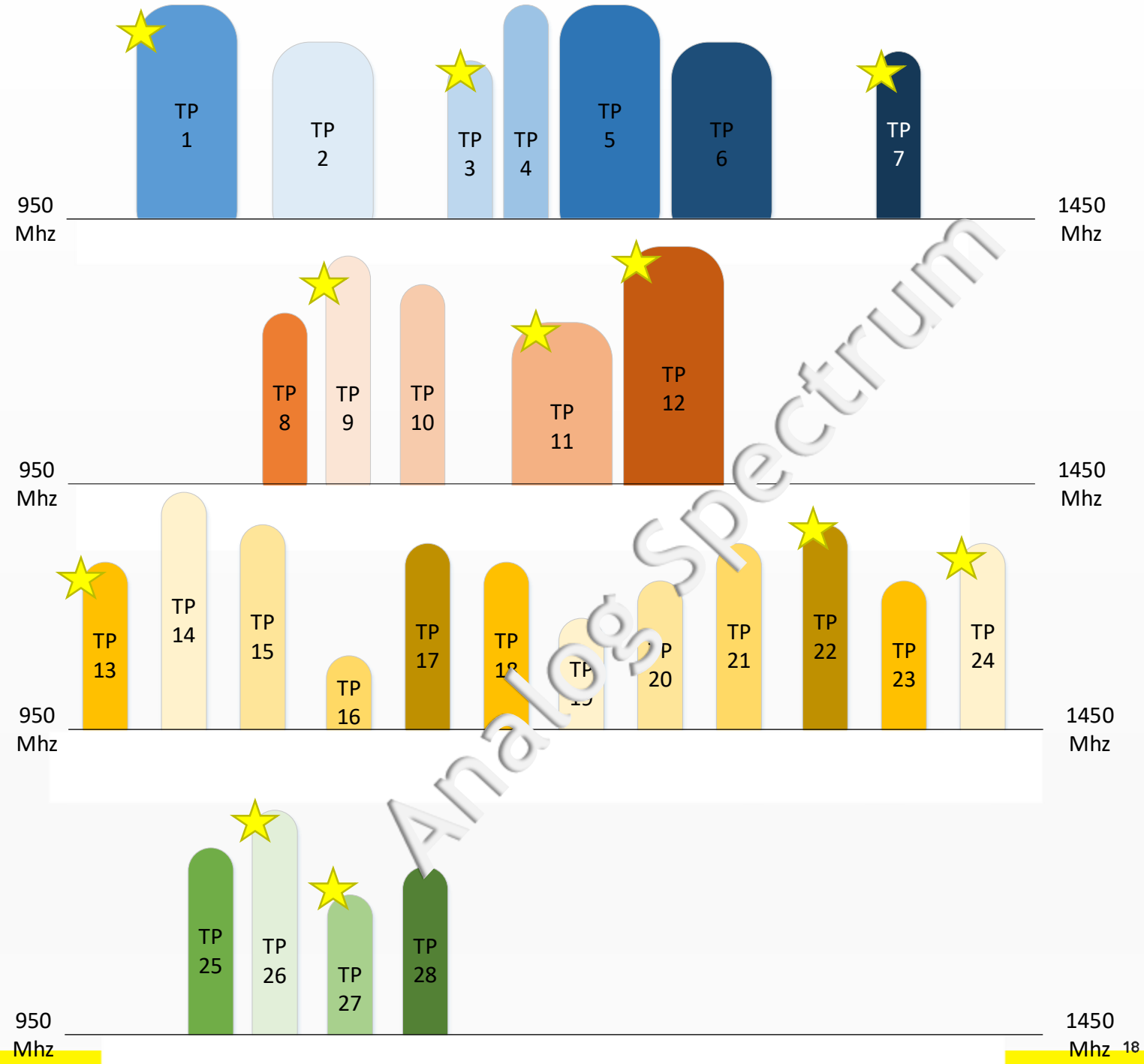
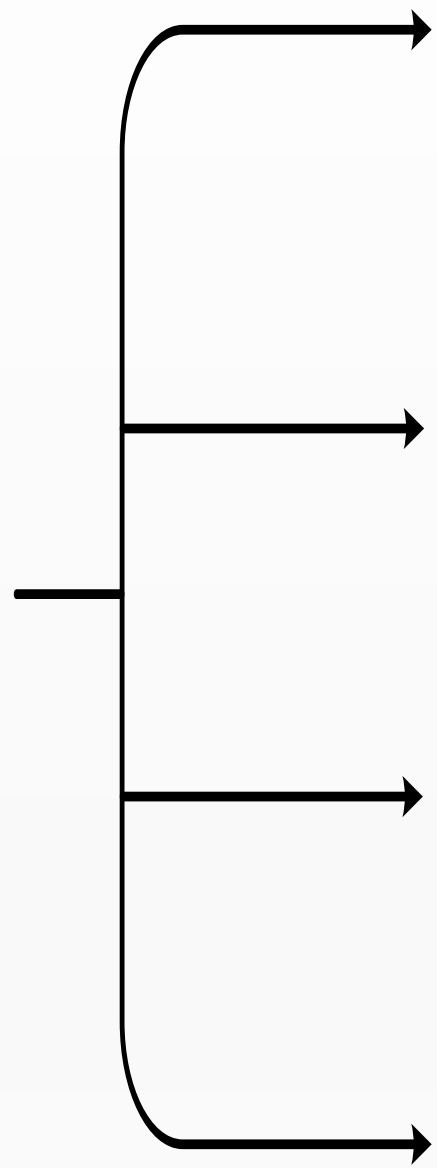

RF over IP Example



4 Polarity

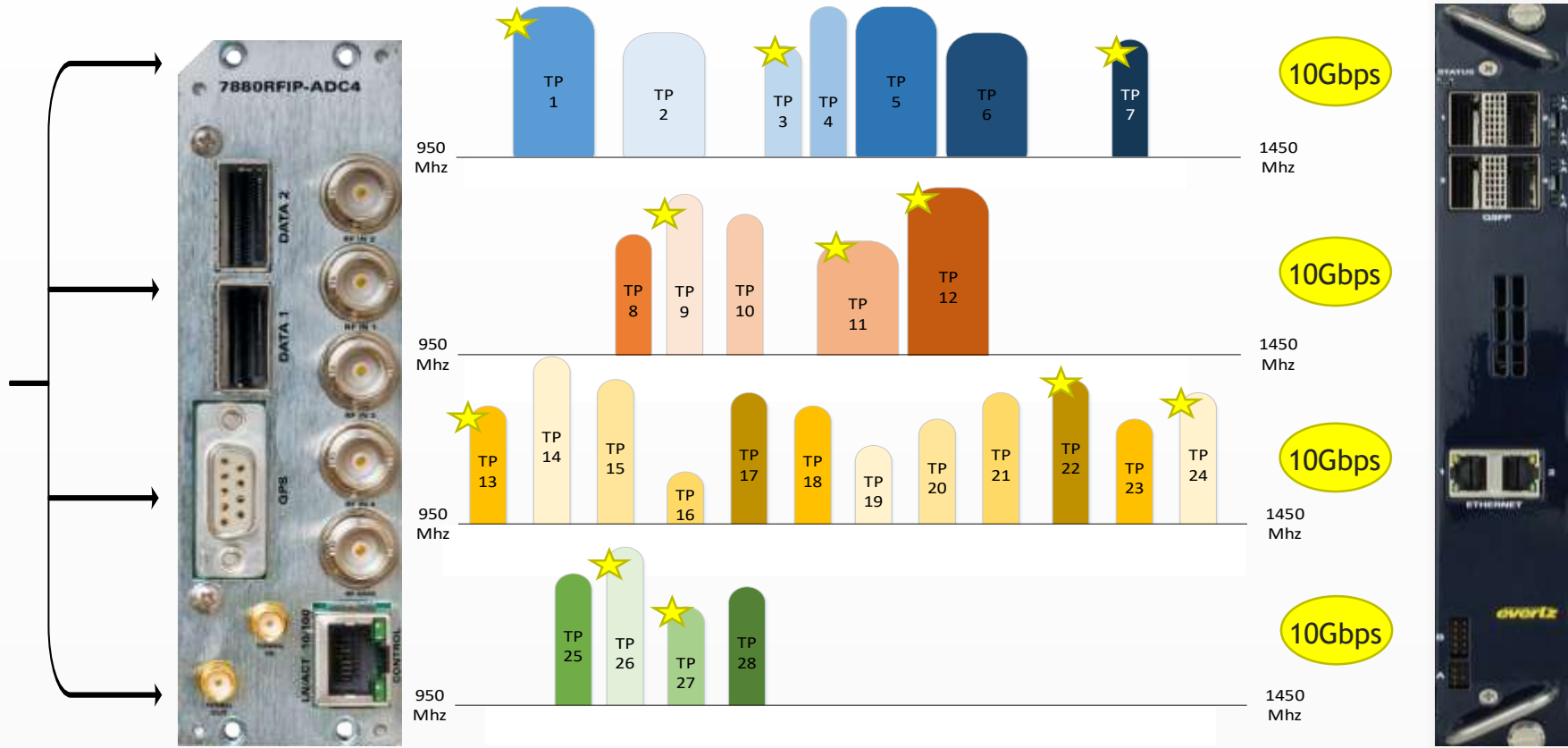

Digital Spectrum

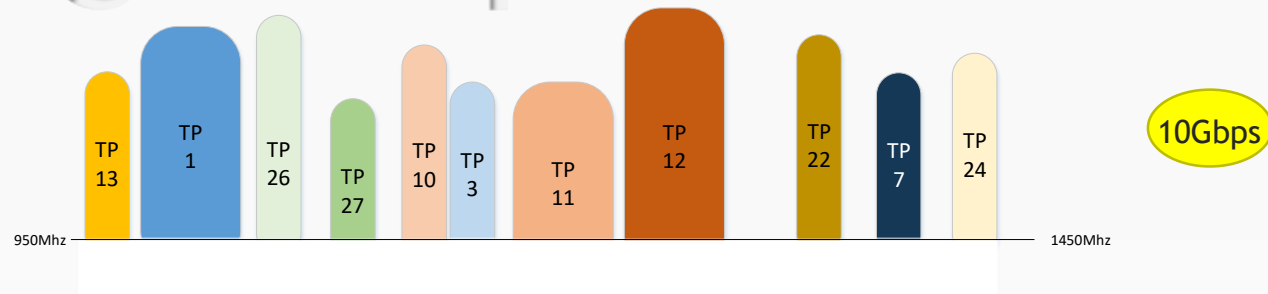

RF over IP with WSP Example

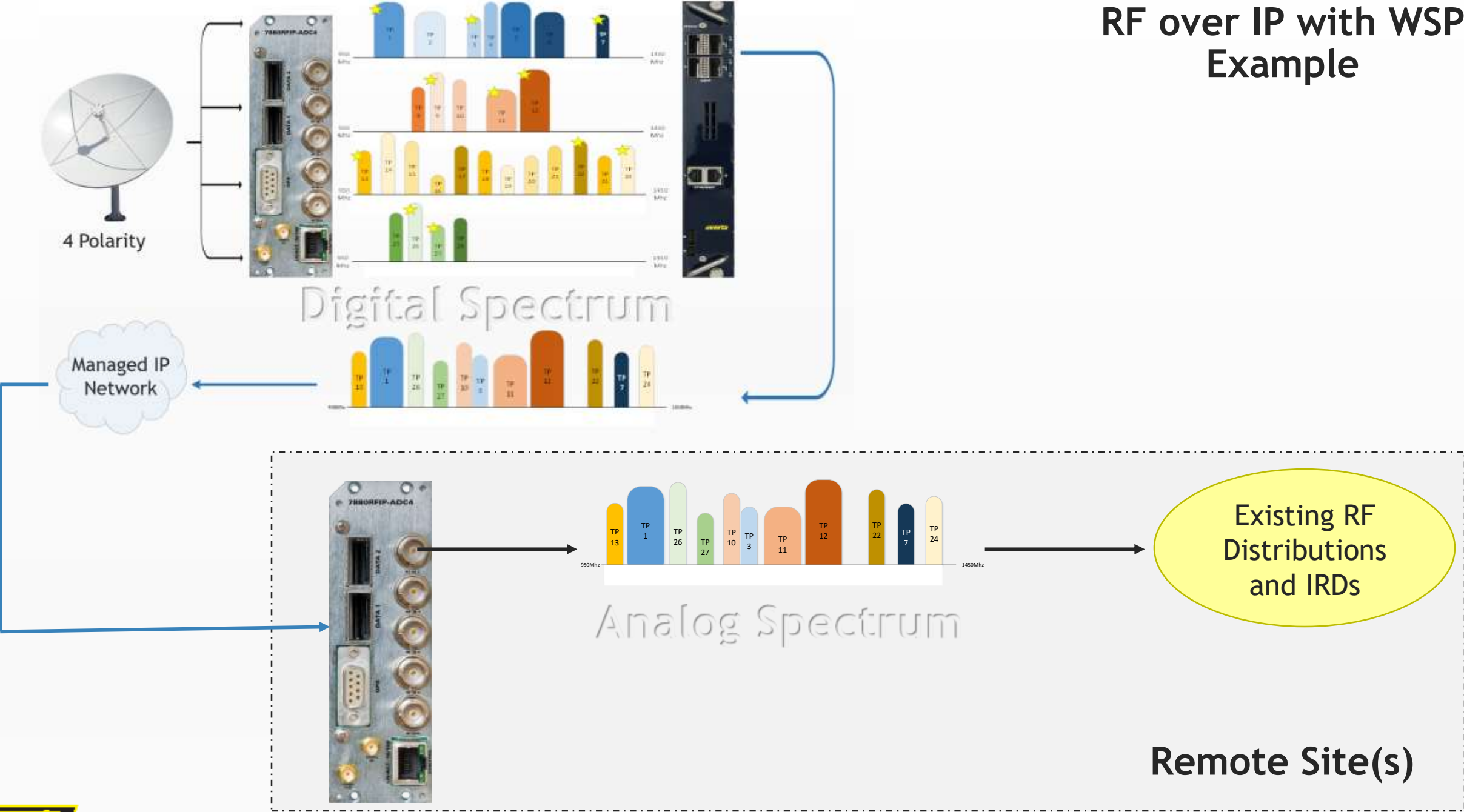

Wideband Signal Processor

Density



- 7x modules can be housed in a 6RU frame - up to 91 carrier streams processing
- 2x modules can be housed in 3RU frame - up to 26x carrier streams processing
- One module can be housed in a 1RU frame - up to 13x carrier streams processing.



Cascading capabilities to create a bigger system



Thank you



evertz.com



@EvertzTV



Evertz